

NO.	NAME	FINISH	Q, TY
01	SMA 180° (Female)	Gold plating	01
02	Hirose (ø1.32) + H.FL Connector	Black	01
03	Heat-shrink tube	Black	01

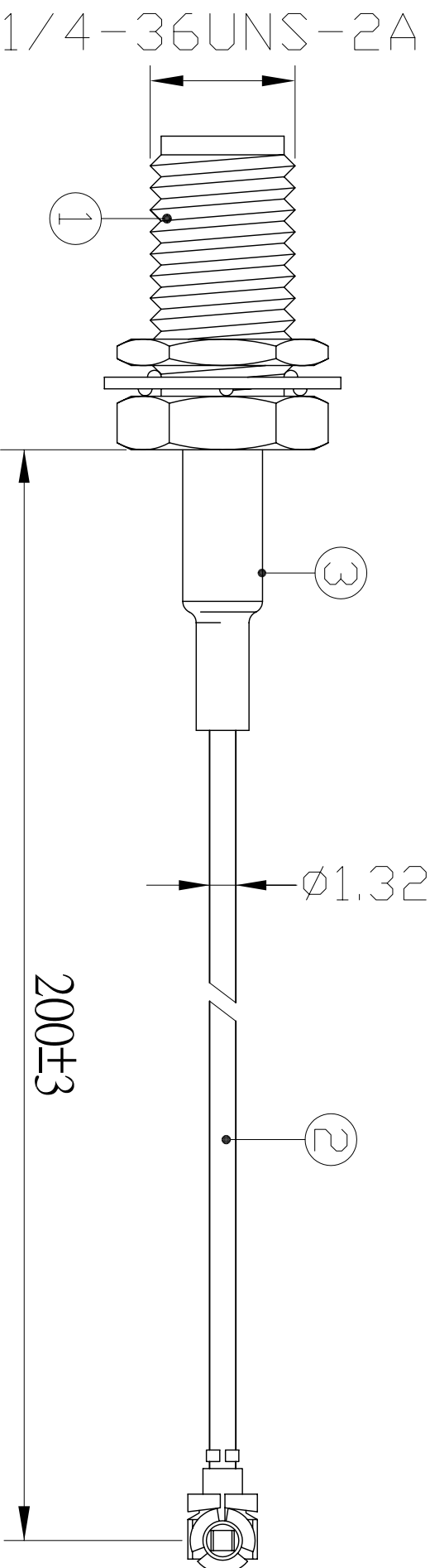

CUSTOMER'S S	MODEL	PARTS NUMBER	FREQUENCY	UNIT	SCALE	DATE	VERSION
				M/M		20070621	1
TOLERANCE	X. XX±0.15	NAME	PARTS NUMBER	APPROVED	CHECKED	DRAWING	DESIGNED
SURFACE ROUGHNESS	\sqrt{S}	APPEARANCE	CP1. 24-20cm-SMA/F-H.FL				



Third angle projection

PROFESSOR

普傑國際股份有限公司